



PHYSITEMP INSTRUMENTS INC

154 Huron Avenue
Clifton NJ 07013 USA
Tel: 973-779-5577
Fax: 973-779-5954

OPERATING MANUAL

TCAT-2LV CONTROLLER

APPENDIX 1:
Installation instructions for HP-1M warming plate
for use with TCAT-2LV and TCAT-2DF controllers

Check contents of package carefully to verify contents comprising:

1. HP-1M Warming Plate
2. 3 foot long connector cable (Other lengths can be made to order)

INSTALLATION INSTRUCTIONS

1. Attach the round 7-pin connector to mating socket on rear of TCAT-2LV or TCAT-2DF. The connector is mechanically polarized to prevent incorrect insertion. Once inserted, rotate the outer ring at the tip of the connector 90° in a clockwise direction to lock in place.
2. Attach opposite end of cable to the HP-1M warming plate. This connector is also polarized to prevent incorrect insertion and has a built-in locking tab to prevent accidental removal. To disconnect from warming plate press down the locking tab and pull back.
3. A Platinum RTD Sensor built into the plate signals the controller to prevent it from overheating. Power to the plate is interrupted if the plate temperature exceeds 42° centigrade. If higher plate control temperatures are required, please call our service department for instructions on how to change the set point.
4. A second sensor (Type T thermocouple), described in the Operating Manual for TCAT-2LV and TCAT-2DF, provides feedback control in the system. For rats this would normally be RET-1 flexible rectal probe and for mice the IT-18 can be used.

If you have questions about a specific application, please call our engineering department at 973-779-5577, ext 15. Or e-mail us at physitemp@aol.com

SPECIFICATIONS

Plate size: 4.37" wide x 8.5" long x .025" thick
Power requirements: 12VDC @2Amps (25watts)
Sensor: Ceramic encapsulated Platinum RTD sensor, Nominal resistance 100ohms @ 0°C

WARRANTY

Physitemp Instruments Inc warrants this product to be free of defects in material or workmanship for a period of 12 months from date of shipment. Repair or replacement will be made at no charge at the discretion of Physitemp if the defect is not the result of misuse or abuse. Physitemp accepts no consequential liability for delay in delivery, alleged faulty performance of the product or any other cause.

6.0 MAINTENANCE, WARRANTY AND SERVICE

6.1 WARRANTY

Physitemp Instruments Inc. warrants this system to be free from defects in material or workmanship for 12 months from date of shipment. Repair or replacement will be made at no charge at the discretion of Physitemp if the defect is not the result of misuse or abuse. Physitemp accepts no consequential liability for delay in delivery, alleged faulty performance of the product or any other cause.

Cables and probes are considered expendable and are not covered by this warranty.

6.2 REPAIRS AND RECALIBRATION

For technical applications information on this instrument contact us at:

Tel: 973-779-5577

Fax: 973-779-5954

E-mail: physitemp@aol.com

In the event that any part of this system is to be returned for repair or recalibration, please pack it with care (in the original packing material if possible) and send it prepaid to:

Service Department
PHYSITEMP INSTRUMENTS INC
154 Huron Avenue
Clifton, NJ 07013 USA

Please include with the instrument:

1. A note describing any problems encountered
2. The name and telephone number of a person we can contact
3. The complete return address for shipping.

For your protection, please pack the item carefully and insure against possible damage or loss.

Physitemp will not be responsible for damage resulting from careless packaging. Please return freight prepaid.

5.0 SPECIFICATIONS TCAT-2LV

Operating Range:	-128°C to +400°C
Digital Readout Resolution:	0.1°C
AC Input Voltage:	100 - 130VAC or 200 - 240VAC, 50 or 60Hz user selectable Fused input module, (6.3Amp, 5 x 20mm fuse)
Output:	Via LVDC power supply
Size:	7 3/8" wide x 10" deep x 4 3/8' high
Weight:	2.8 lbs
Other features:	Red output lamp will be on when load is powered Adjustable viewing angle

4.0 OPERATING INSTRUCTIONS

The instruction label from the top of the instrument is reprinted here in case it is ever defaced.

FEEDBACK SENSOR	AUXILIARY OUTPUT	OFF/ON POWER SWITCH
----------------------------	-----------------------------	------------------------------------

TCAT-2LV CONTROLLER

OPERATING INSTRUCTIONS

The TCAT-2 Controller parameters are set at the factory for for the specific load supplied with it. If the TCAT-2 has not been so supplied, see the Operating Manual for adjustment of the control parameters

1. Connect the thermocouple sensor to the blue Feedback Sensor Socket on the rear panel and position the sensor.
2. Connect the load (heating pad or blanket) to the Low Voltage 7-pin Output Socket on the rear of the controller.
3. Connect the controller power cord to a suitable AC outlet.
4. Turn on controller Power Switch (rear panel).
5. Set the control temperature:
 - a) Press Function Key. SP will appear on the display.
 - b) Press UP or DOWN buttons and hold until desired control temperature is reached.
 - c) Press Function key again to enter new control temperature.

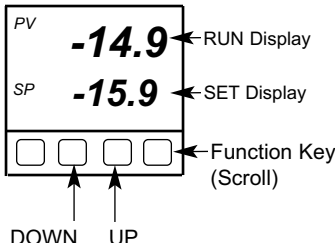

← RUN Display

← SET Display

← Function Key (Scroll)

DOWN UP

SPECIFICATIONS:

Operating Range: -128°C to +400°C

Resolution: 0.1°C

AC Input Voltage: 110-130VAC or 220-240VAC, 50 or 60Hz (see Operating Manual)

SPECIAL DISPLAY INDICATIONS:

Red lamp will be illuminated when power is being supplied to load.

VIEWING ANGLE

The two front feet can be flipped down to adjust the viewing angle. Rotate feet down and towards the front until they lock in position. To return to original position, pull down slightly, then rotate back.

Serial Number:
19201

Made in USA

PHYSITEMP INSTRUMENTS INC

154 Huron Avenue
Clifton, NJ 07013 USA
Tel: 973-779-5577, Fax: 973-779-5954
www.physitemp.com

3.0 SETTING UP THE TCAT-2LV CONTROLLER

- 3.1 Connect a suitable load to the LVDC output
- 3.2 Insert a type T thermocouple feedback sensor into the blue socket. Ensure that the sensor tip is securely attached to the load at an appropriate location. Call our Engineering Applications Department (1-800-452-8510) for more information on sensor placement.
- 3.3 Connect the AC power cord to the AC input module and to any suitable AC outlet.
- 3.4 The auxiliary AC output socket is available for additional equipment and is activated by the input module power switch.



REAR PANEL CONNECTIONS

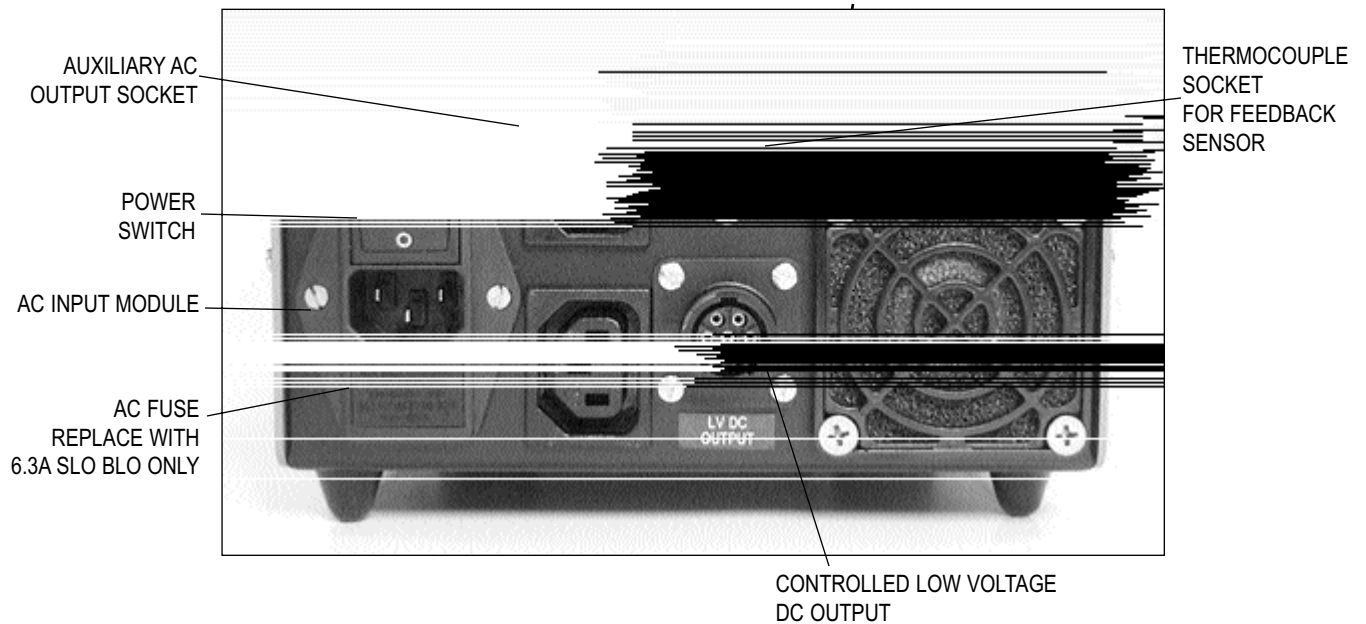

TCAT-2 CONTROLLER

1.0 GENERAL DESCRIPTION

1.1 The TCAT-2 is a general purpose autotuning controller for a variety of laboratory applications. The TCAT-2AC provides two time-proportioning controlled AC outlets for the control of resistive loads such as heat lamps or warming blankets. It can also be adapted to many different types of load (maximum 500 Watts.)

The TCAT-2LV provides a low voltage DC output for electrically sensitive applications where AC frequencies will interfere with monitoring devices. It can be supplied with a variety of different DC power supplies depending on the load requirements. The TCAT-2LV uses a dual set point control circuit to prevent a heating element from overshooting the control point. This is recommended in applications such as animal warming tables or blankets where thermal lag in the control system is an issue and might lead to burns.

The TCAT-2DF combines features of both the instruments described above.

A type T thermocouple probe is used as the temperature feedback sensor and any of Physitemp's extensive line of probes can be used for this application.

All the TCAT-2 instruments operate on a 110V - 230V AC supply.

2.0 UNPACKING AND CHECKING THE PACKAGE CONTENTS

The following items should be found in the packing box:

- TCAT-2 controller
- AC Line cord
- Probes and other items as ordered.

OPERATING MANUAL

TCAT-2LV CONTROLLER

CONTENTS

SECTION		PAGE
1.0	GENERAL DESCRIPTION	2
2.0	UNPACKING AND CHECKING CONTENTS	2
3.0	SETTING UP THE TCAT-2LV	3
4.0	OPERATING INSTRUCTIONS	4
5.0	SPECIFICATIONS	5
6.0	MAINTENANCE, WARRANTY AND SERVICE	6
Appendix 1	Installation Instructions for HP-1M Warming Plate	